

**SolidWorks Educational Edition.
For Instructional Use Only.**

UNLESS OTHERWISE SPECIFIED:
DIMENSIONS ARE IN MILLIMETERS
SURFACE FINISH:
TOLERANCES:
LINEAR: DIN ISO 2768-m
ANGULAR:

Universiteit Gent

Vakgroep Fysica & Sterrenkunde
Krijgslaan 281 S9 B-9000 Gent BELGIUM
+32 (0)9 264 47 74



DRAWN :
NAME G Wauters
DATE 27/4/2015
FINISH:

TITLE:

Refractor Project

MATERIAL:
Plywood

DWG NO. RefractorMount

A4

ITEM NO.	PART NUMBER	DESCRIPTION	QTY.
1	TripodTopDisk	Tripod Top Disk	1
2	TripodTopHingeBlockLarge	Tripod Hinge L	6
3	TripodTopHingeBlockSmall	Tripod Hinge S	6
4	TripodBaseTube	Tripod Hinge Tube	3
5	TripodTopRotDisk	Tripod Rotation Disk	1
6	TripodTopTopDisk	Tripod Top Disk	1
7	ISO 1207 - M6 x 45 --- 38N		1
8	Hexagon Nut ISO 4032 - M6 - W - N		1
9	TripodLegSide	Tripod Leg Side	6
10	TripodLegBase	Tripod Leg Base	3
11	TripodSpreaderSupport	Tripod Spreader Support	3
12	ISO 1207 - M8 x 80 --- 38N		3
13	TubeClampTop	Clamp Top	4
14	TubeClampSide	Clamp Side	2
15	TubeClampDisk	Clamp Disk	2
16	DIN 912 M5 x 50 --- 22N		4
17	Bresser80900Scope		1
18	AltAzBase	AltAz Base	1
19	AltAzSide	AltAz Side	2
20	AltAzFront	AltAz Front	1
21	TripodSpreaderPlate	Tripod Spreader Plate	1

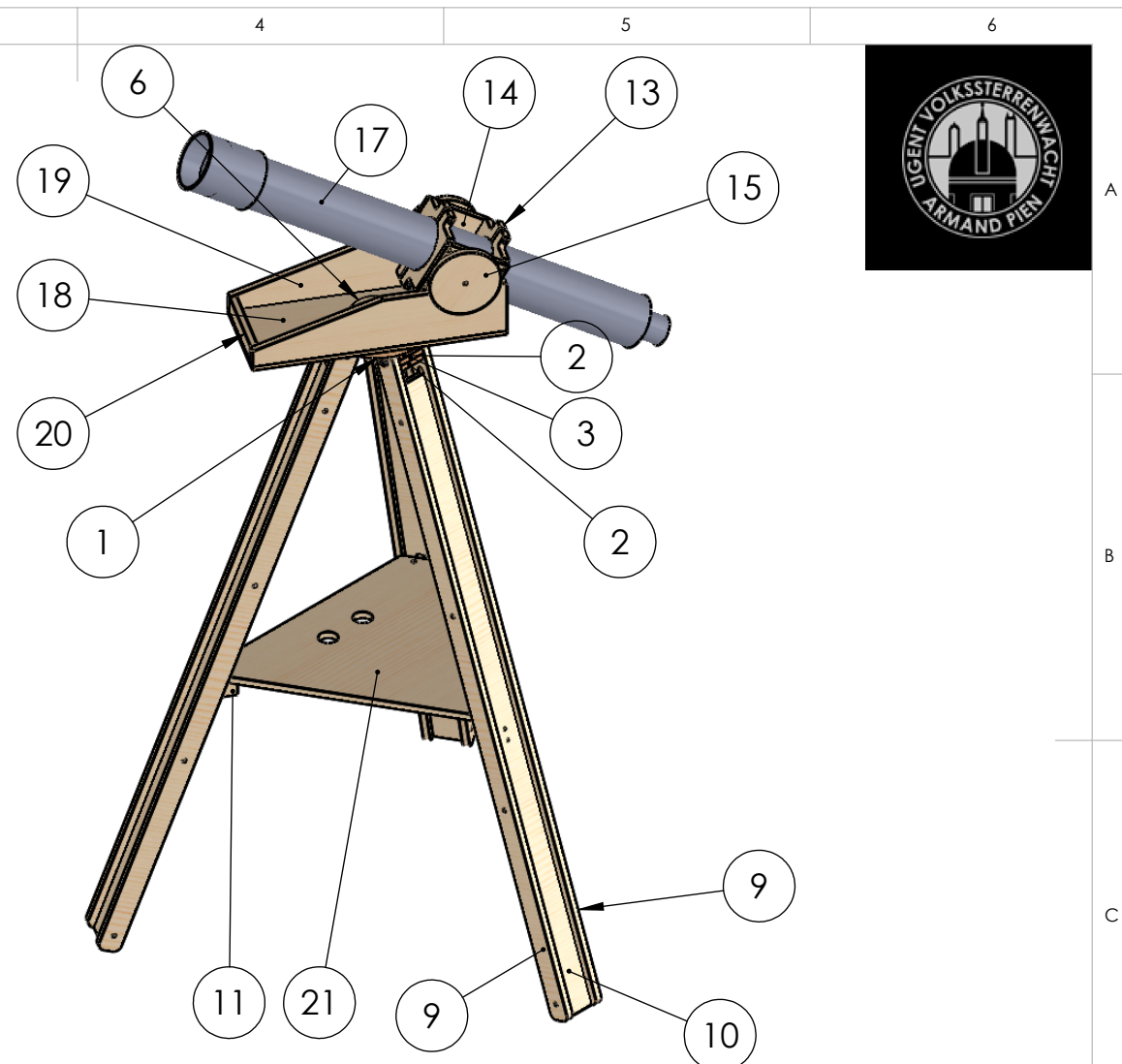

UNLESS OTHERWISE SPECIFIED:
 DIMENSIONS ARE IN MILLIMETERS
 SURFACE FINISH:
 TOLERANCES:
 LINEAR: DIN ISO 2768-m
 ANGULAR:

DRAWN :
 NAME: G Wauters
 DATE: 27/4/2015
 FINISH:

MATERIAL:
 Plywood

www.kijkerbouw.be

Universiteit Gent
 Vakgroep Fysica & Sterrenkunde
 Krijgslaan 281 S9 B-9000 Gent BELGIUM
 +32 (0)9 264 47 74

UNIVERSITEIT GENT

TITLE:
Refractor Project

DWG NO.: RefractorMountBOM

A4

SCALE: 1:12

SHEET 1 OF 1

**SolidWorks Educational Edition.
 For Instructional Use Only.**

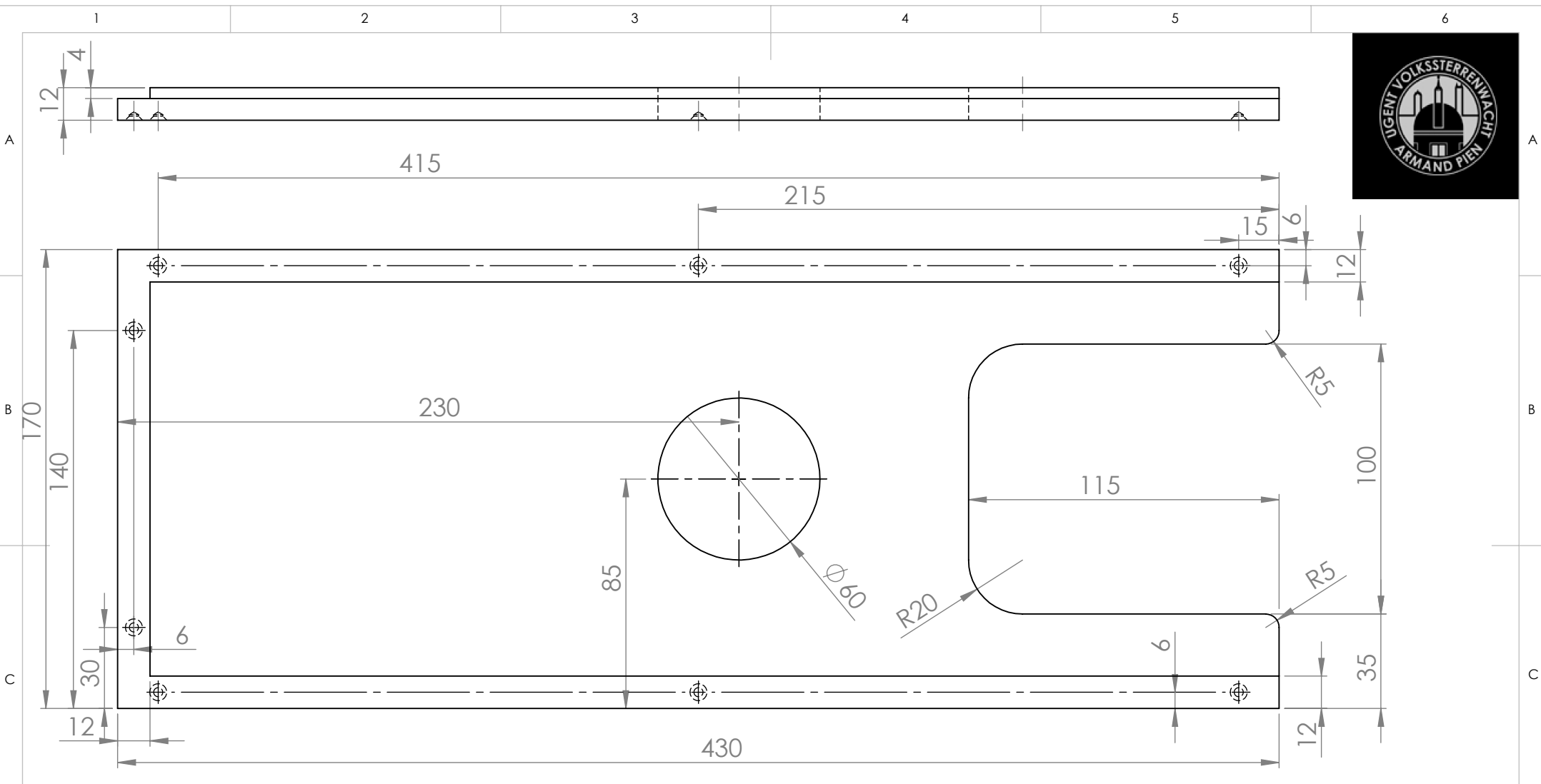

UNLESS OTHERWISE SPECIFIED:
 DIMENSIONS ARE IN MILLIMETERS
 SURFACE FINISH:
 TOLERANCES:
 LINEAR: DIN ISO 2768-m
 ANGULAR:

Universiteit Gent
 Vakgroep Fysica & Sterrenkunde
 Krijgslaan 281 S9 B-9000 Gent BELGIUM
 +32 (0)9 264 47 74



DRAWN :
 NAME: Guy W
 DATE: 4/5/2015
 FINISH:

TITLE:
AltAz Base

MATERIAL:
Berken 12mm

DWG NO. **AltAzBase** A4

**SolidWorks Educational Edition.
 For Instructional Use Only.**

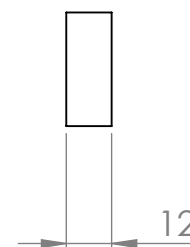
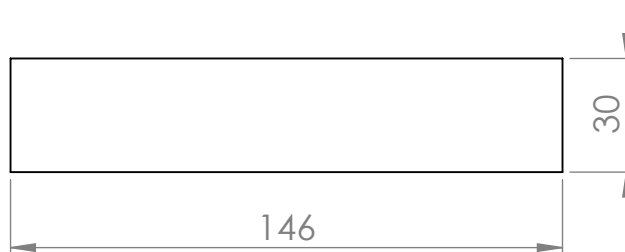

**SolidWorks Educational Edition.
For Instructional Use Only.**

UNLESS OTHERWISE SPECIFIED:
DIMENSIONS ARE IN MILLIMETERS
SURFACE FINISH:
TOLERANCES:
LINEAR: DIN ISO 2768-m
ANGULAR:

Universiteit Gent
Vakgroep Fysica & Sterrenkunde
Krijgslaan 281 S9 B-9000 Gent BELGIUM
+32 (0)9 264 47 74



DRAWN :	
NAME	Guy W
DATE	4/5/2015
FINISH:	

TITLE:

AltAz Front

MATERIAL:
Berken 12mm

DWG NO.	AltAzFront	A4
---------	------------	----

www.kijkerbouw.be

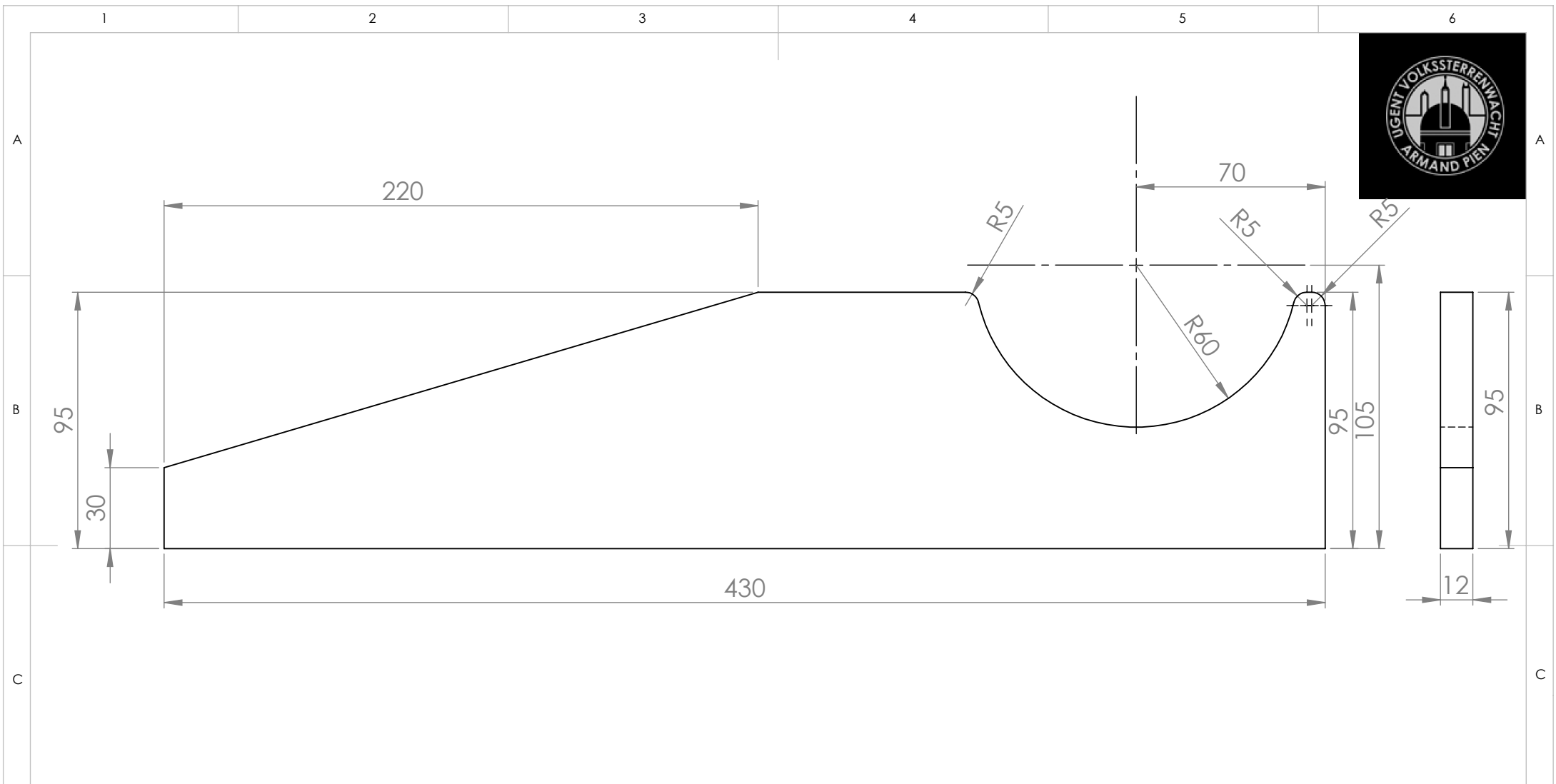

**SolidWorks Educational Edition.
For Instructional Use Only.**

UNLESS OTHERWISE SPECIFIED: DIMENSIONS ARE IN MILLIMETERS SURFACE FINISH: TOLERANCES: LINEAR: DIN ISO 2768-m ANGULAR:		Universiteit Gent Vakgroep Fysica & Sterrenkunde Krijgslaan 281 S9 B-9000 Gent BELGIUM +32 (0)9 264 47 74		
DRAWN :		TITLE:		
NAME	GW	<h1 style="text-align: center;">AltAz Side</h1>		
DATE	4/5/2015			
FINISH:				
MATERIAL:	Berken 12mm	DWG NO.	AltAzSide	A4
www.kijkerbouw.be		SCALE:1:2	SHEET 1 OF 1	

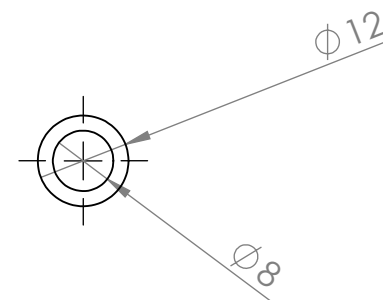
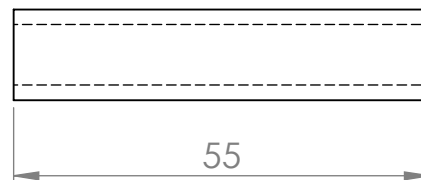

Kanten breken
Break sharp edges

**SolidWorks Educational Edition.
For Instructional Use Only.**

UNLESS OTHERWISE SPECIFIED:
DIMENSIONS ARE IN MILLIMETERS
SURFACE FINISH:
TOLERANCES:
LINEAR: DIN ISO 2768-m
ANGULAR:

Universiteit Gent
Vakgroep Fysica & Sterrenkunde
Krijgslaan 281 S9 B-9000 Gent BELGIUM
+32 (0)9 264 47 74



DRAWN :
NAME: Guy W
DATE: 4/5/2015
FINISH:

TITLE:
Tripod Hinge Tube

MATERIAL:
Alu dia12 D2

DWG NO. TripodBaseTube

A4

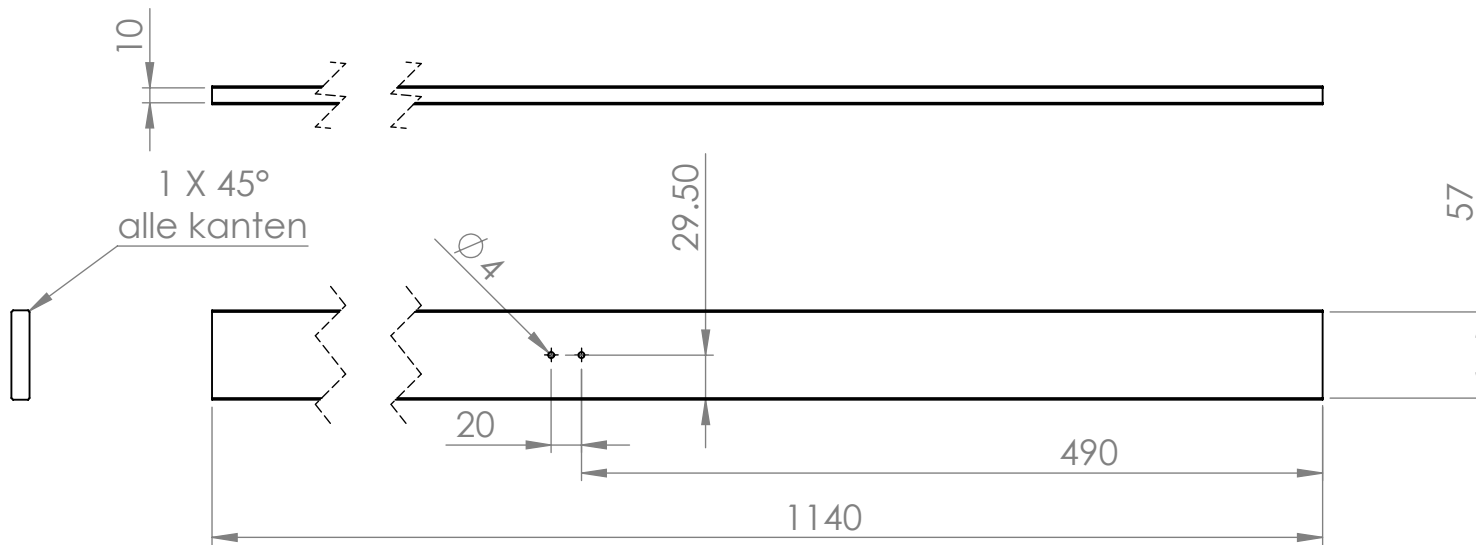

**SolidWorks Educational Edition.
For Instructional Use Only.**

UNLESS OTHERWISE SPECIFIED: DIMENSIONS ARE IN MILLIMETERS SURFACE FINISH: TOLERANCES: LINEAR: DIN ISO 2768-m ANGULAR:		Universiteit Gent Vakgroep Fysica & Sterrenkunde Krijgslaan 281 S9 B-9000 Gent BELGIUM +32 (0)9 264 47 74			
DRAWN :		TITLE:			
NAME	Guy W	<h1 style="text-align: center;">Tripod Leg Base</h1>			
DATE	4/5/2015				
FINISH:					
MATERIAL:	Berken 12mm	DWG NO.	TripodLegBase	A4	
www.kijkerbouw.be		SCALE:1:5	SHEET 1 OF 1		

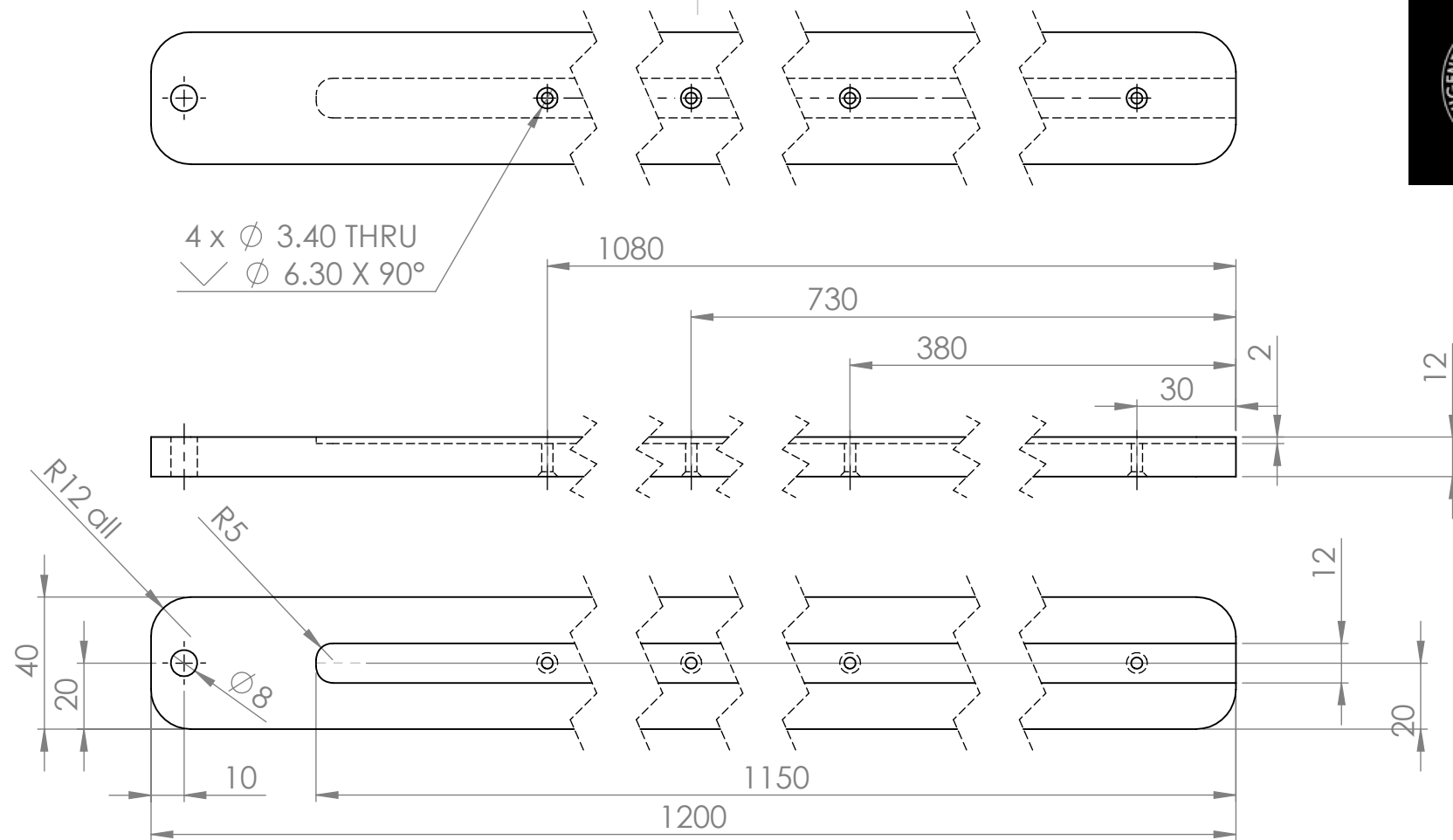

4 x ϕ 3.40 THRU
 \checkmark ϕ 6.30 X 90°

R12 all

R5

ϕ 8

40

20

10

1080

730

380

30

2

12

12

20

1150

1200

**SolidWorks Educational Edition.
 For Instructional Use Only.**

UNLESS OTHERWISE SPECIFIED:
 DIMENSIONS ARE IN MILLIMETERS
 SURFACE FINISH:
 TOLERANCES:
 LINEAR: DIN ISO 2768-m
 ANGULAR:

Universiteit Gent
 Vakgroep Fysica & Sterrenkunde
 Krijgslaan 281 S9 B-9000 Gent BELGIUM
 +32 (0)9 264 47 74



DRAWN :
 NAME: Guy W
 DATE: 4/5/2015
 FINISH:

TITLE:
Tripod Leg Side

MATERIAL:
 Berken 12mm

DWG NO. TripodLegSide
 A4

www.kijkerbouw.be

SCALE:1:2

SHEET 1 OF 1

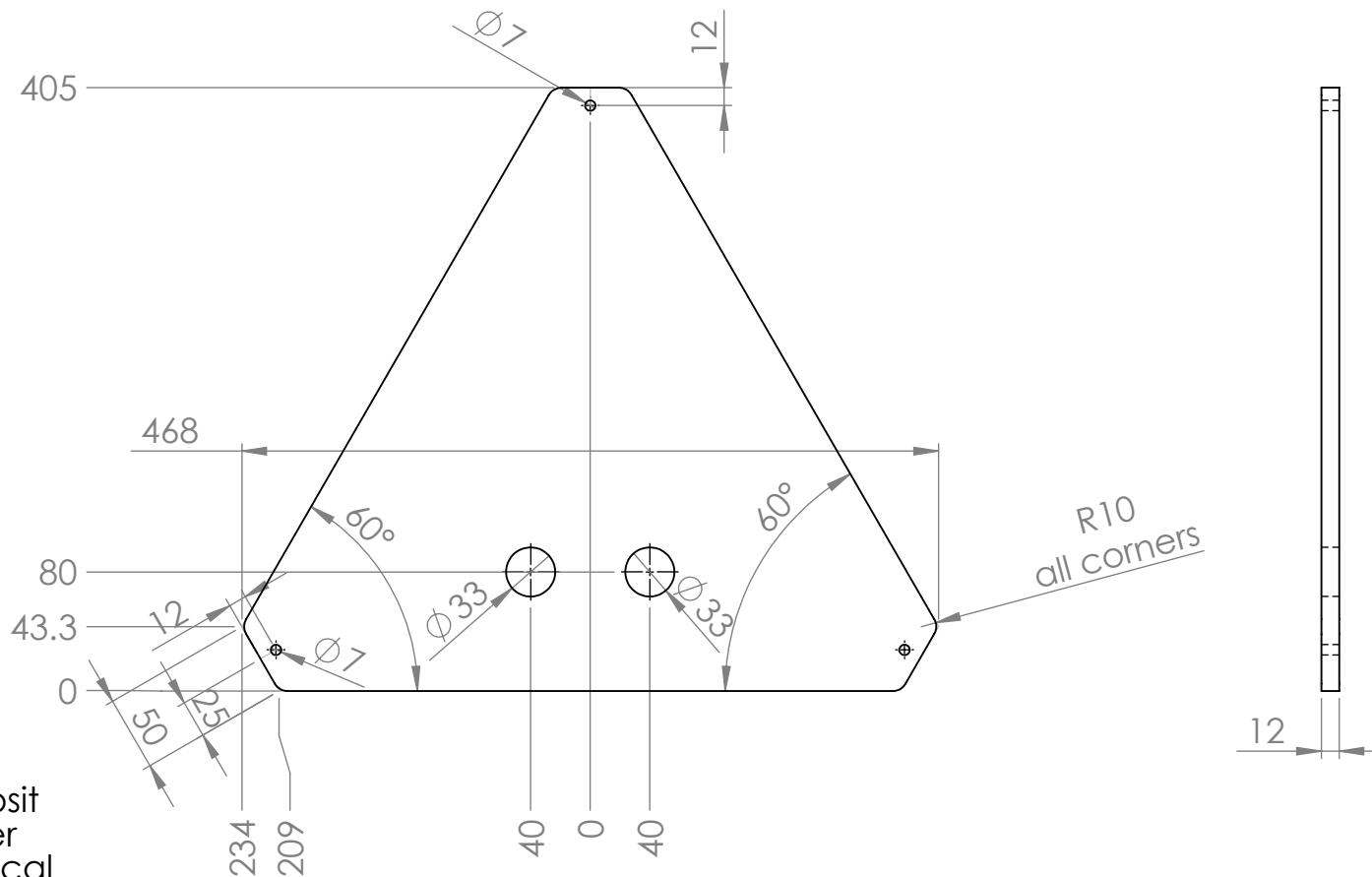

Opposit
corner
identical

UNLESS OTHERWISE SPECIFIED:
DIMENSIONS ARE IN MILLIMETERS
SURFACE FINISH:
TOLERANCES:
LINEAR: DIN ISO 2768-m
ANGULAR:

Universiteit Gent

Vakgroep Fysica & Sterrenkunde
Krijgslaan 281 S9 B-9000 Gent BELGIUM
+32 (0)9 264 47 74



DRAWN :
NAME: Guy W
DATE: 4/5/2015
FINISH:

TITLE:

Tripod Spreader Plate

MATERIAL:
Berken 12mm

DWG NO.: TripodSpreaderPlate

A4

www.kijkerbouw.be

SCALE:1:5

SHEET 1 OF 1

**SolidWorks Educational Edition.
For Instructional Use Only.**

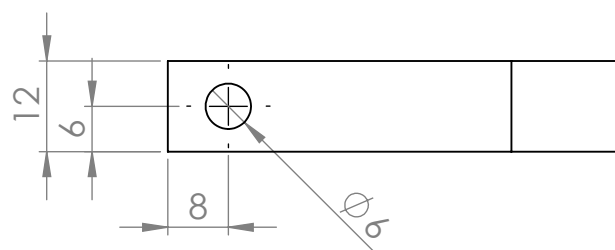
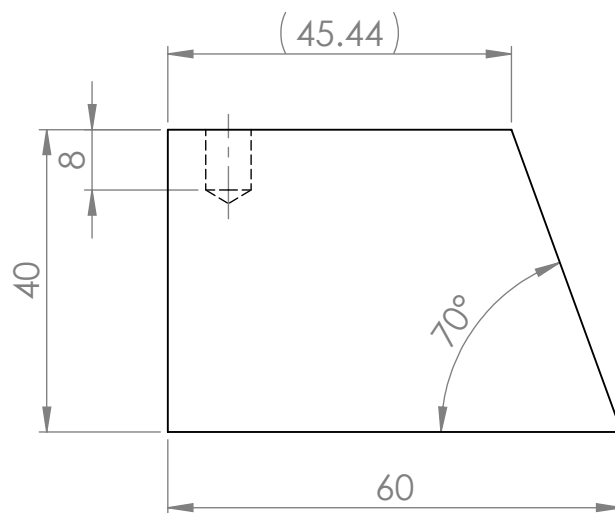

**SolidWorks Educational Edition.
For Instructional Use Only.**

UNLESS OTHERWISE SPECIFIED:
DIMENSIONS ARE IN MILLIMETERS
SURFACE FINISH:
TOLERANCES:
LINEAR: DIN ISO 2768-m
ANGULAR:

Universiteit Gent
Vakgroep Fysica & Sterrenkunde
Krijgslaan 281 S9 B-9000 Gent BELGIUM
+32 (0)9 264 47 74



DRAWN :	
NAME	Guy W
DATE	4/5/2015
FINISH:	

TITLE:
Tripod Spreader Support

MATERIAL:
Berken 12mm

DWG NO. **TripodSpreaderSupport** **A4**

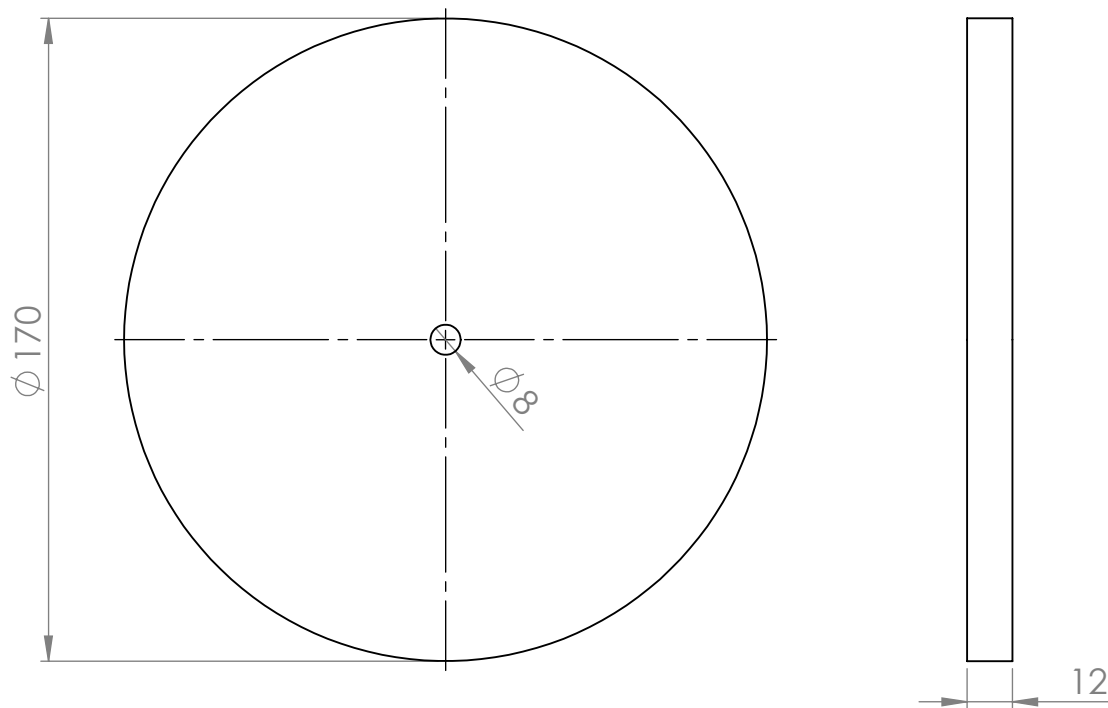

**SolidWorks Educational Edition.
For Instructional Use Only.**

UNLESS OTHERWISE SPECIFIED:
DIMENSIONS ARE IN MILLIMETERS
SURFACE FINISH:
TOLERANCES:
LINEAR: DIN ISO 2768-m
ANGULAR:

Universiteit Gent
Vakgroep Fysica & Sterrenkunde
Krijgslaan 281 S9 B-9000 Gent BELGIUM
+32 (0)9 264 47 74



DRAWN :	
NAME	GW
DATE	4/5/2015
FINISH:	

TITLE:

Tripod Top Disk

MATERIAL:
Berken 12mm

DWG NO. **TripodTopDisk**

A4

www.kijkerbouw.be

SCALE:1:2

SHEET 1 OF 1



**SolidWorks Educational Edition.
For Instructional Use Only.**

UNLESS OTHERWISE SPECIFIED:
DIMENSIONS ARE IN MILLIMETERS
SURFACE FINISH:
TOLERANCES:
LINEAR: DIN ISO 2768-m
ANGULAR:

Universiteit Gent
Vakgroep Fysica & Sterrenkunde
Krijgslaan 281 S9 B-9000 Gent BELGIUM
+32 (0)9 264 47 74



DRAWN :	
NAME	Guy W
DATE	4/5/2015
FINISH:	

TITLE:	<h1>Tripod Hinge L</h1>	

MATERIAL:
Berken 12mm

DWG NO.	TripodTopHingeBlockLarge	A4
---------	--------------------------	----

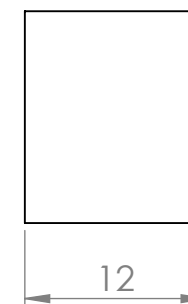

**SolidWorks Educational Edition.
For Instructional Use Only.**

UNLESS OTHERWISE SPECIFIED:
DIMENSIONS ARE IN MILLIMETERS
SURFACE FINISH:
TOLERANCES:
LINEAR: DIN ISO 2768-m
ANGULAR:

Universiteit Gent
Vakgroep Fysica & Sterrenkunde
Krijgslaan 281 S9 B-9000 Gent BELGIUM
+32 (0)9 264 47 74



DRAWN :	
NAME	Guy W
DATE	4/5/2015
FINISH:	

TITLE:	<h1>Tripod Hinge S</h1>	

MATERIAL:
Berken 12mm

DWG NO.	TripodTopHingeBlockSmall	A4
---------	--------------------------	----

www.kijkerbouw.be

SCALE:2:1	SHEET 1 OF 1
-----------	--------------

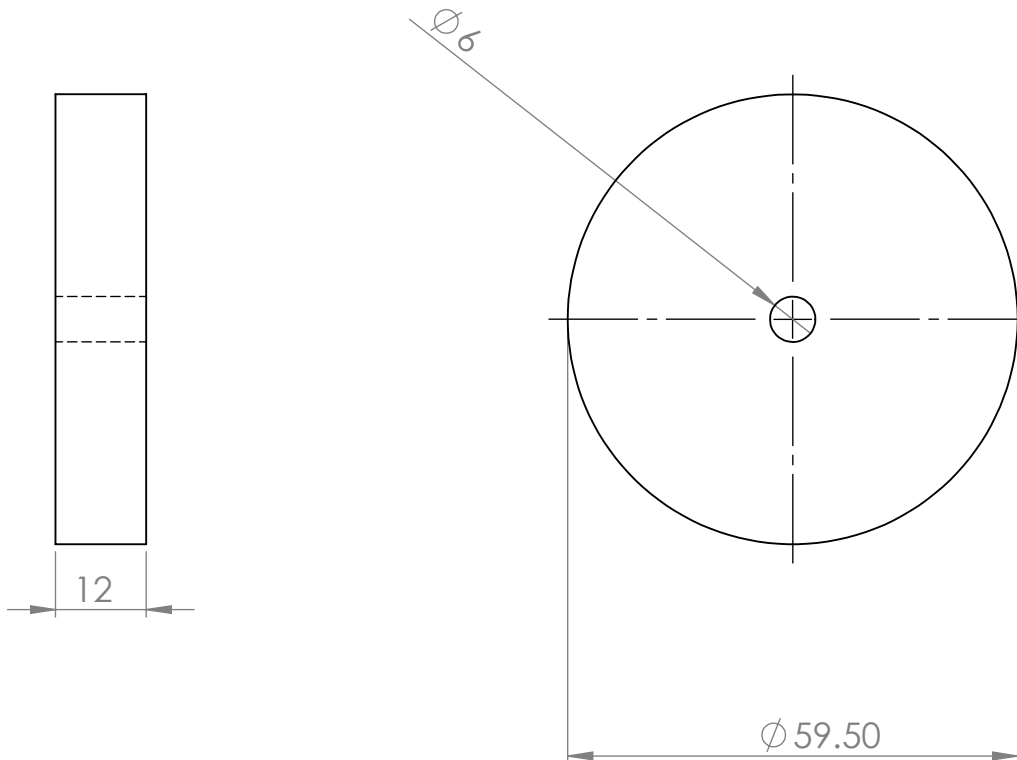

**SolidWorks Educational Edition.
For Instructional Use Only.**

UNLESS OTHERWISE SPECIFIED: DIMENSIONS ARE IN MILLIMETERS SURFACE FINISH: TOLERANCES: LINEAR: DIN ISO 2768-m ANGULAR:		Universiteit Gent Vakgroep Fysica & Sterrenkunde Krijgslaan 281 S9 B-9000 Gent BELGIUM +32 (0)9 264 47 74		
DRAWN :		TITLE:		
NAME	GW	Tripod Rotation Disk		
DATE	20/05/2015			
FINISH:				
MATERIAL:	Berken Multiplex 12mm	DWG NO.	TripodTopRotDisk	A4
www.kijkerbouw.be		SCALE:1:1	SHEET 1 OF 1	

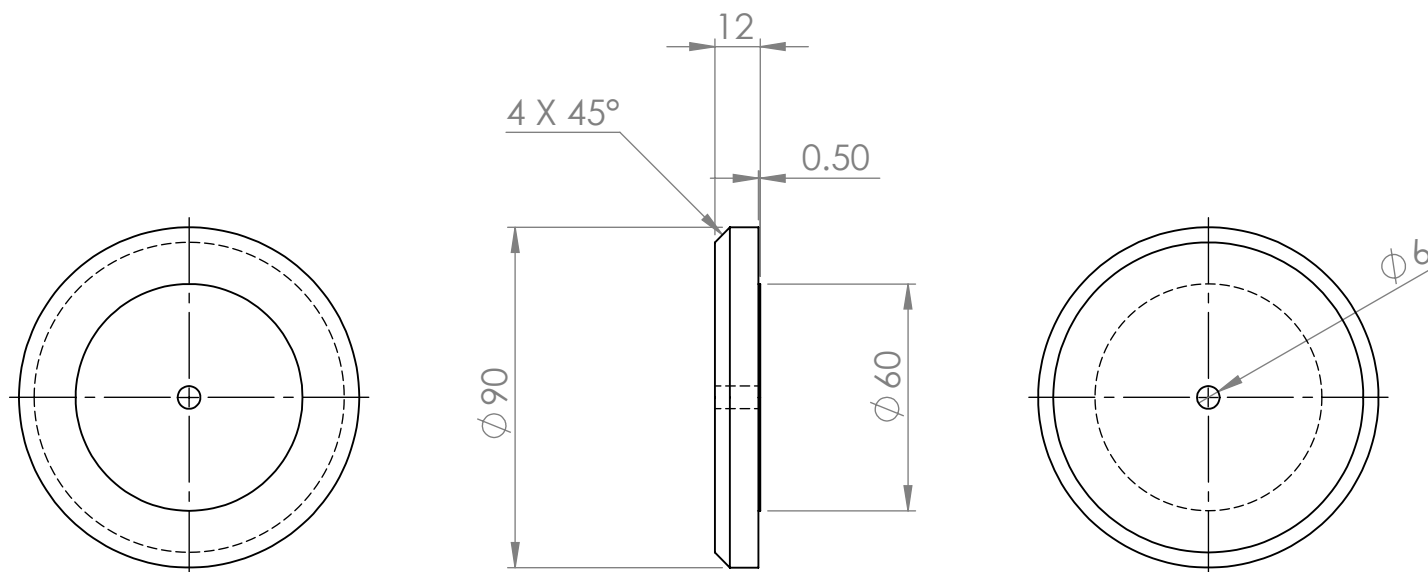

**SolidWorks Educational Edition.
For Instructional Use Only.**

UNLESS OTHERWISE SPECIFIED: DIMENSIONS ARE IN MILLIMETERS SURFACE FINISH: TOLERANCES: LINEAR: DIN ISO 2768-m ANGULAR:		Universiteit Gent Vakgroep Fysica & Sterrenkunde Krijgslaan 281 S9 B-9000 Gent BELGIUM +32 (0)9 264 47 74			
DRAWN :		TITLE:			
NAME	GW	<h1 style="text-align: center;">Tripod Top Disk</h1>			
DATE	20/5/2015				
FINISH:					
MATERIAL:	Berken Multiplex 12mm	DWG NO.	TripodTopTopDisk	A4	
www.kijkerbouw.be		SCALE:1:2	SHEET 1 OF 1		

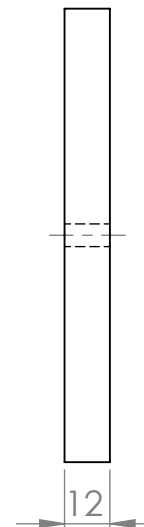
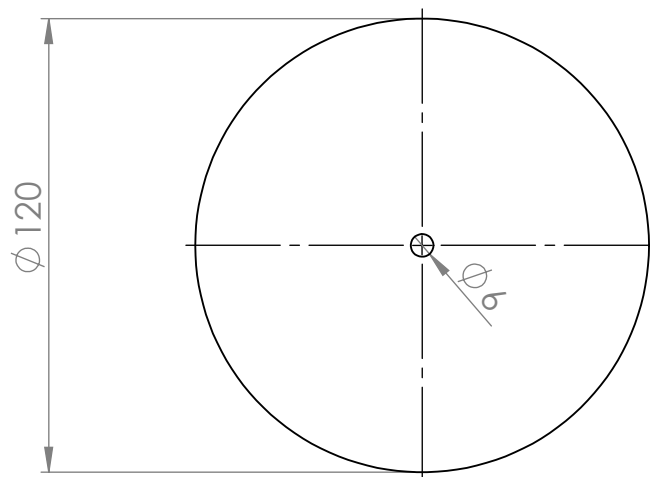

Kanten breken
Break Sharp Edges

**SolidWorks Educational Edition.
For Instructional Use Only.**

UNLESS OTHERWISE SPECIFIED:
DIMENSIONS ARE IN MILLIMETERS
SURFACE FINISH:
TOLERANCES:
LINEAR: DIN ISO 2768-m
ANGULAR:

Universiteit Gent
Vakgroep Fysica & Sterrenkunde
Krijgslaan 281 S9 B-9000 Gent BELGIUM
+32 (0)9 264 47 74



DRAWN :	
NAME	Guy W
DATE	4/5/2015
FINISH:	

TITLE:	<h1>Clamp Disk</h1>	
--------	---------------------	--

MATERIAL:
Berken 12mm

DWG NO.	TubeClampDisk	A4
---------	---------------	----

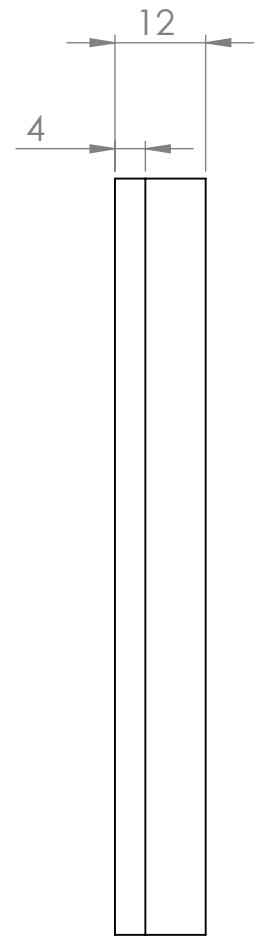
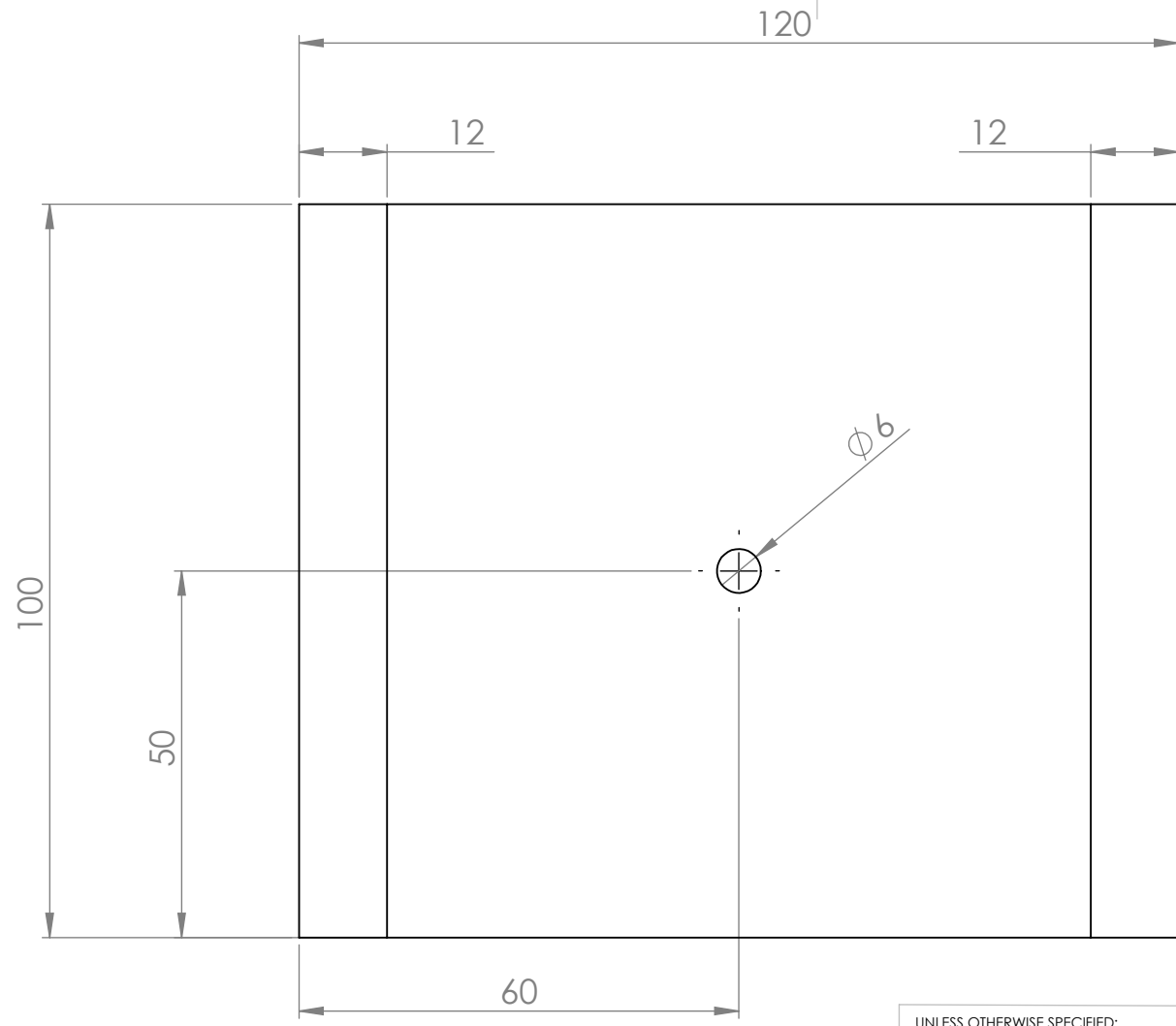

**SolidWorks Educational Edition.
For Instructional Use Only.**

UNLESS OTHERWISE SPECIFIED: DIMENSIONS ARE IN MILLIMETERS SURFACE FINISH: TOLERANCES: LINEAR: DIN ISO 2768-m ANGULAR:	
DRAWN :	
NAME	Guy W
DATE	4/5/2015
FINISH:	
MATERIAL:	Berken 12mm
www.kijkerbouw.be	

Universiteit Gent Vakgroep Fysica & Sterrenkunde Krijgslaan 281 S9 B-9000 Gent BELGIUM +32 (0)9 264 47 74		
TITLE: <h1 style="text-align: center;">Clamp Side</h1>		
DWG NO.	TubeClampSide	A4
SCALE:1:1	SHEET 1 OF 1	

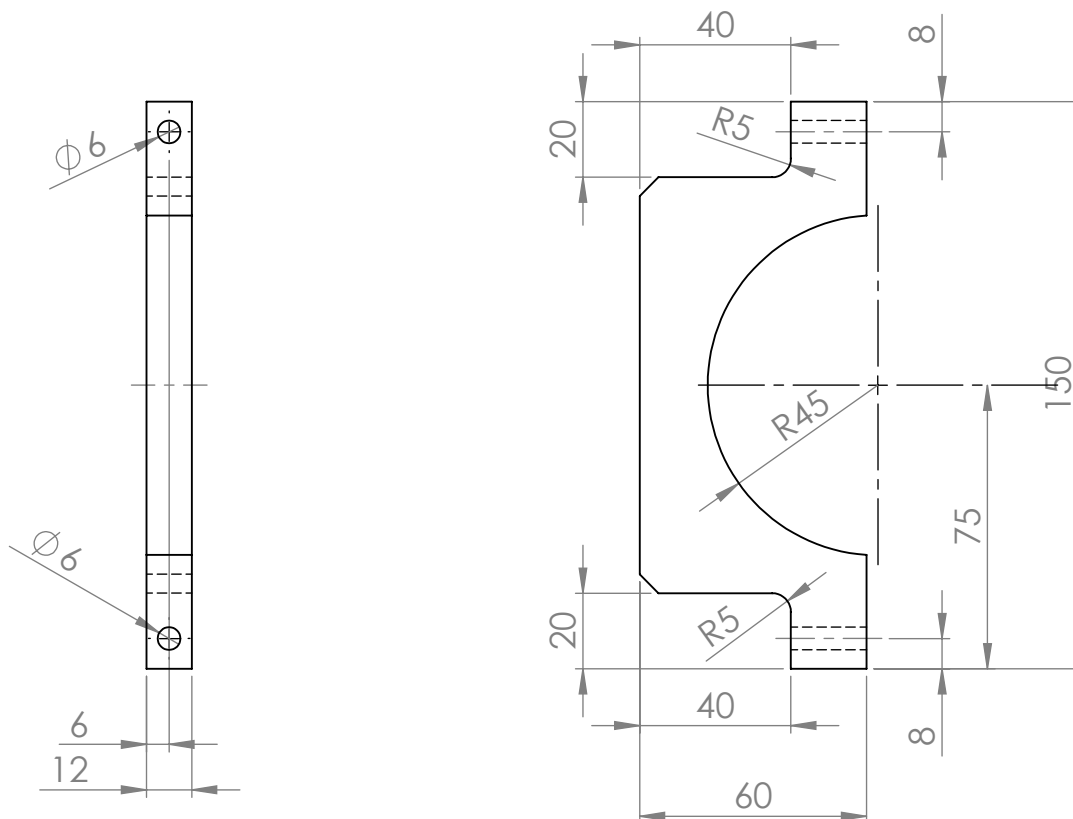

**SolidWorks Educational Edition.
For Instructional Use Only.**

UNLESS OTHERWISE SPECIFIED:
DIMENSIONS ARE IN MILLIMETERS
SURFACE FINISH:
TOLERANCES:
LINEAR: DIN ISO 2768-m
ANGULAR:

Universiteit Gent
Vakgroep Fysica & Sterrenkunde
Krijgslaan 281 S9 B-9000 Gent BELGIUM
+32 (0)9 264 47 74



DRAWN :	
NAME	Guy W
DATE	4/5/2015
FINISH:	

TITLE:	<h1>Clamp Top</h1>	
--------	--------------------	--

MATERIAL:	Berken 12mm
-----------	-------------

DWG NO.	TubeClampTop	A4
---------	--------------	----