

ITEM NO.	PART NUMBER	DESCRIPTION	QTY.
1	TripodBaseTube	Tripod Hinge Tube	3
2	TripodTopRotDisk	Tripod Rotation Disk	1
3	TripodTopTopDisk	Tripod Top Disk	1
4	ISO 1207 - M6 x 45 --- 38N		1
5	Hexagon Nut ISO 4032 - M6 - W - N		1
6	TripodLegSide	Tripod Leg Side	6
7	TripodLegBase	Tripod Leg Base	3
8	TripodSpreaderSupport	Tripod Spreader Support	3
9	ISO 1207 - M8 x 80 --- 38N		3
10	TubeClampTop	Clamp Top	4
11	TubeClampSide	Clamp Side	2
12	TubeClampDisk	Clamp Disk	2
13	DIN 912 M5 x 50 --- 22N		4
14	Bresser80900Scope		1
15	AltAzBase	AltAz Base	1
16	AltAzSide	AltAz Side	2
17	AltAzFront	AltAz Front	1
18	TripodSpreaderPlate	Tripod Spreader Plate	1
19	TripodTopBase	Tripod Top Base	1
20	TripodHingeBlock	Tripod Hinge Block	3

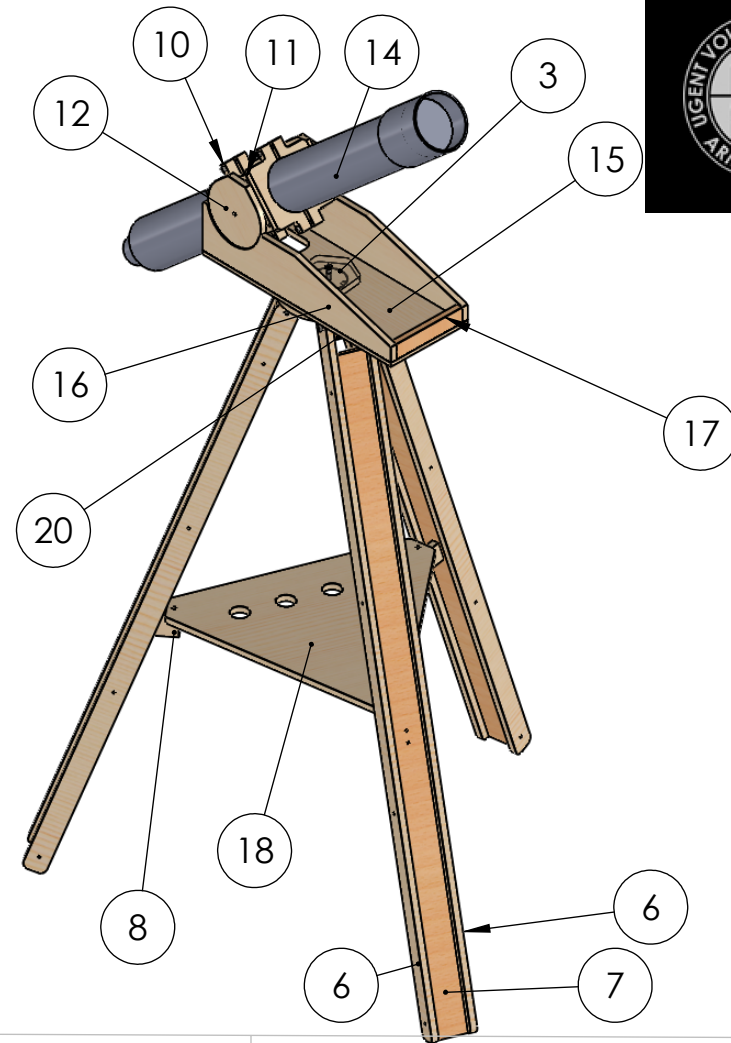

UNLESS OTHERWISE SPECIFIED:
 DIMENSIONS ARE IN MILLIMETERS
 SURFACE FINISH:
 TOLERANCES:
 LINEAR: DIN ISO 2768-m
 ANGULAR:

Universiteit Gent
 Vakgroep Fysica & Sterrenkunde
 Krijgslaan 281 S9 B-9000 Gent BELGIUM
 +32 (0)9 264 47 74



DRAWN :
 NAME: G Wauters
 DATE: 27/4/2015
 FINISH:

TITLE:
Refractor Project

MATERIAL:
Plywood

DWG NO.: RefractorMount
 A4

**SolidWorks Educational Edition.
 For Instructional Use Only.**