

1. Precrease in fourths. Valley-fold the two edges to the centre line.

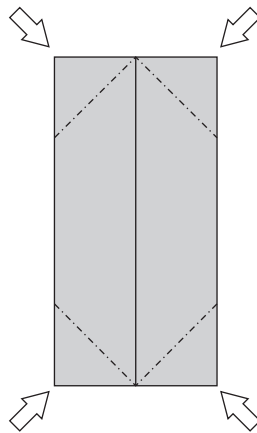

2. Reverse-fold the four corners.

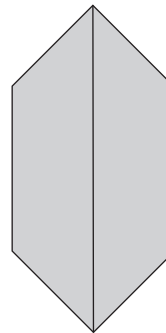

3. Turn over.

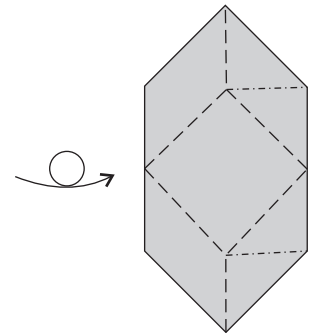

4. Rabbit-ear both corners.

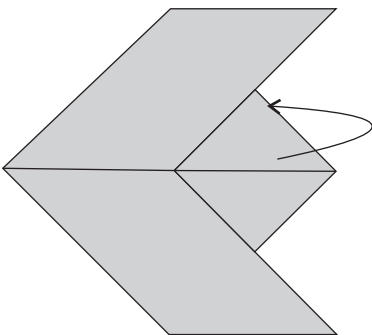

5. Fold the flap to the left.

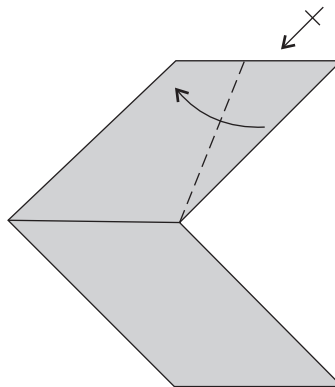

6. Valley-fold one flap to the left. Repeat behind.

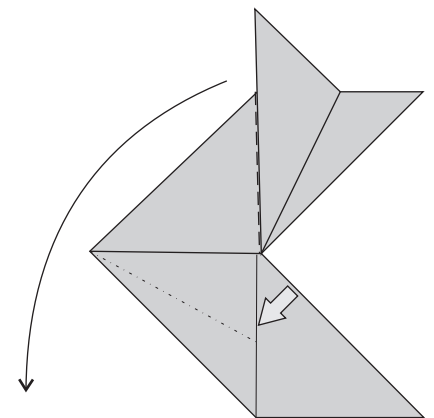

7. Reverse-fold at the inside.

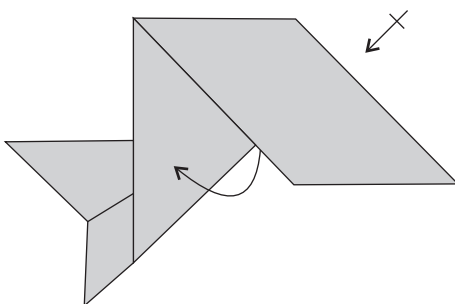

8. Pull out some trapped paper. Repeat behind.

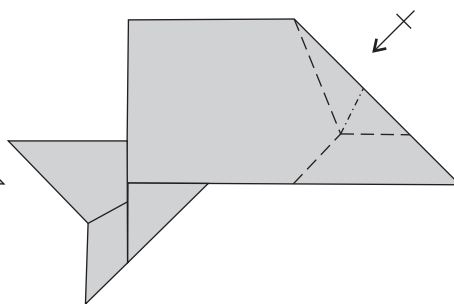

9. Rabbit-ear one flap. Repeat behind.

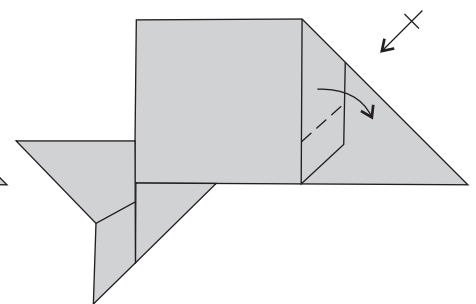

10. Valley-fold to the right. Repeat behind.

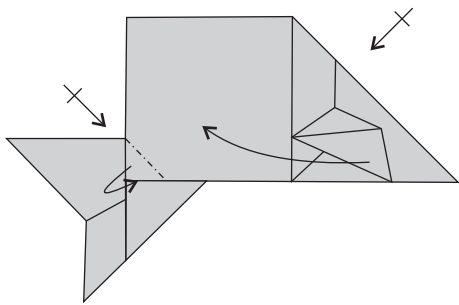

11. Fold the flap to the left. Repeat behind. Mountain-fold some paper underneath. Repeat behind.

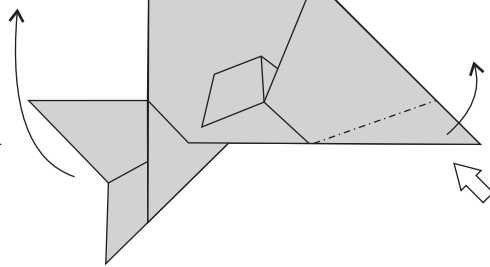

12. Slide the tail upwards and press to flatten. Reverse-fold the corner upwards.

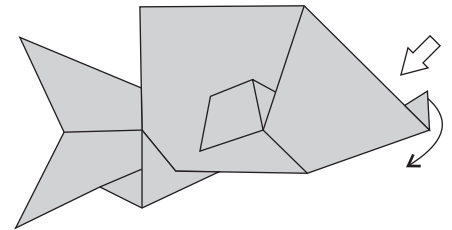

13. Reverse-fold the tip down.

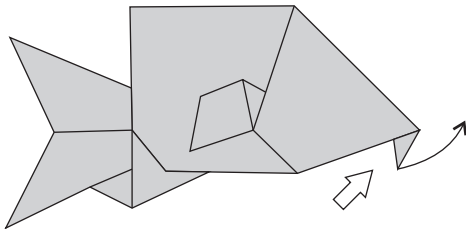

14. Reverse-fold the tip to the right.

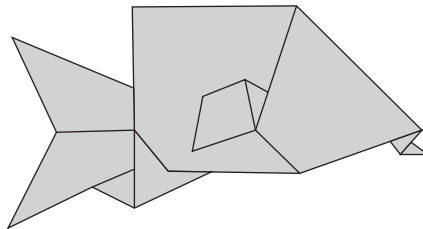

15. Finished tilapia.
 Model: Tom Defoirdt, 2008.
 Diagrams: Tom Defoirdt, 2013.
www.tomdefoirdt.tk
www.flickr.com/verduiveld